

Contact Information:

**FOTILE AMERICA LLC.**

Add: 6 Campus Dr, Suite 210, Parsippany, NJ 07054

Toll Free: 888-315-0366

Web: [www.fotileglobal.com/us](http://www.fotileglobal.com/us)

Email: [serviceusa@fotile.com](mailto:serviceusa@fotile.com)

**FOTILE**



FOTILE Website FOTILE Wechat FOTILE YouTube



RANGE HOODS | COOKTOPS | OVENS | STEAM OVENS | MICROWAVE OVENS

# GET TO KNOW FOTILE

- Innovation, the core of FOTILE manufacturing
- More than 2500 national patents, including more than 400 innovation patents (by Mar 2019)
- Leading the world in kitchen technology, FOTILE never stops.



For more than 22 years, FOTILE has continually exceeded expectations in kitchens all around the globe, supporting a happy, healthy lifestyle for families like yours. Currently, FOTILE has 117 sales branches, and FOTILE products are available for purchase in home appliance chains, department stores, exclusive FOTILE stores, and online.

As of 2016, when FOTILE America established its headquarters in Parsippany, New Jersey, FOTILE products are available to US consumers through our carefully-selected FOTILE Chartered Agents.

With a brand that's worth \$2.8 billion, FOTILE is more than a kitchen appliance company; we're an industry leader, and the #1 choice among consumers in over 20 different countries. As of March 2019, FOTILE holds over 2,500 patents including over 400 invention patents.

Our dedication to ongoing research and development has allowed FOTILE to proudly create innovative advanced technology products, raising the standards for premium built-in kitchen appliances.

Our mission is simple: For the happiness of millions of families.

## ENHANCING YOUR HOME THROUGH INNOVATION



Member of HVI, the most authoritative and credible institution in North America



reddot design award



FOTILE's V Series Range Hoods Provide Thorough Ventilation.

Designed to keep up with even the busiest home kitchen's needs.

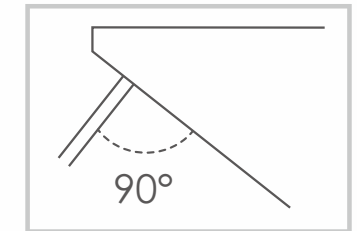

**90° Angled Baffle Plate**  
 Opens automatically when the range hood is turned on, guiding smoke upwards and creating a barrier to prevent you from breathing in harmful smoke and grease.

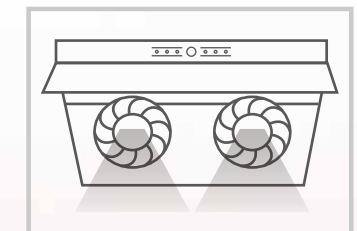

**FOTILE's Proprietary Double Centrifuge Fan System**  
 Places the fans closer to the surface than traditional range hoods, maximizing the unit's speed and efficiency for maximum smoke extraction.

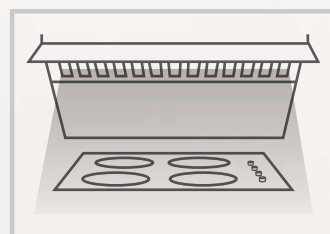

**Expansive Coverage Area**  
 Installed at a 45° angle, the V-Series Range Hoods provide a large ventilation area, proactively drawing in smoke and grease before they can spread. The 30-inch range hood provides coverage for an area measuring 6 square feet, while the 36-inch range hood boasts 7 square feet of coverage.

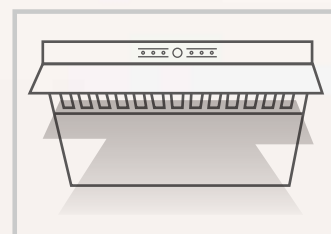

**Oversized Smoke Intake**  
 Spanning evenly from side to side, FOTILE's range hood effectively covers every burner for a clean, smoke-free kitchen.



## Everything You Need In A Range Hood



### Screen Lock For Easy Cleaning

Hold the LOCK SCREEN button for 2 seconds to ensure your screen will stay in place so you can clean with a damp cloth.



### LED Lights

Easily navigate around your stove with up to 500 lx for improved visibility.



### Auto Delay

Eliminate lingering smoke and other odors with your range hood's DELAYED SHUTOFF feature, keeping the fan on for an additional 2 minutes after you're ready to leave the kitchen.



### 90° Baffle Plate

Enjoy cooking in comfort, with the hard partition separating you from unpleasant odors and smoke.



### Extra-Large Grease & Oil Cup

It helps separate oil from smoke, regardless of the amount of food you're cooking, allowing you to prepare more meals with less frequent cleaning.



### Removable, Dishwasher-Safe Filter

Cleaning your filter is quick and easy, thanks to its convenient, folding design.





JQG7501



JQG7501.G



JQG7502



JQG7502.G



JQG9001

<b>Control Mode</b>	Touch	Touch	
<b>Smoke Baffle Plate</b>	Auto	Auto	
<b>Switch Color</b>	/	/	
<b>Panel Color</b>	Onyx Black	Silver Grey	
<b>Size (inch)</b>	<b>Width</b>	29 7/8	29 7/8
	<b>Depth</b>	18 1/4	18 1/4
	<b>Height</b>	17 7/16-46 7/16	17 7/16-46 7/16
<b>Oil Filter</b>	One Folding Oil Filter	One Folding Oil Filter	
<b>Oil Cup</b>	One Oversized Oil Cup	One Oversized Oil Cup	
<b>Time Delay</b>	Y	Y	
<b>Screen Lock</b>	Y	Y	
<b>Power</b>	120V/60Hz	120V/60Hz	
<b>Noise Level</b>	54dB	54dB	
<b>Light</b>	3Wx2 (LED)	3Wx2 (LED)	
<b>Motor Power</b>	256W	256W	
<b>Installation</b>	Undercabinet/Wall mounted	Undercabinet/Wall mounted	

	Button	Button	Touch
	Always Open	Always Open	Auto
	Black	Silver	/
	Onyx Black	Silver Grey	Onyx Black
	29 7/8	29 7/8	35 7/8
	18 1/4	18 1/4	18 1/4
	17 7/16-46 7/16	17 7/16-46 7/16	17 7/16-46 7/16
	One Folding Oil Filter	One Folding Oil Filter	Two Oil Filters
	One Oversized Oil Cup	One Oversized Oil Cup	Two Oil Cups
	/	/	Y
	/	/	Y
	120V/60Hz	120V/60Hz	120V/60Hz
	54dB	54dB	54dB
	3Wx2 (LED)	3Wx2 (LED)	3Wx2 (LED)
	256W	256W	256W
	Undercabinet/Wall mounted	Undercabinet/Wall mounted	Undercabinet/Wall mounted



3.2in

**Quiet, Low-Speed Extraction  
Ideal For Lightly Frying**

Even the simplest recipes sometimes produce smoke and other unpleasant odors. FOTILE's ultra-sensitive Smart Wing-Like Surround Suction Plate keeps your kitchen clean and quiet by trapping these vapors and removing them. Using smart sensors, the suction plate automatically sets fan speed accordingly while lowering the Surround Suction Plate height by 3.2 inches for quick, effortless ventilation.

3.2in

**Sleek, Modern Design**

When switched to the OFF position, the Smart Suction Plate and inner smoke chamber are automatically tucked inside the unit's flat configuration, creating an elegant, modern aesthetic.



**Smart Smoke Detection**

For fast, thorough extraction, your FOTILE range hood's Smart Wing-Like Surround Suction Plate automatically adjusts its elevation, lowering by 3.2-4.7 inches, based on the volume of smoke, grease, and vapor detected. Smoke has virtually no chance of escaping!



4.7in

**Heavy-Duty Extraction  
Ideal For Heavy Smoke And Grease**

Cooking with high-heat, stir-frying, and deep frying are all great examples of cooking styles that can quickly cause a kitchen to fill up with smoke. Thankfully, FOTILE W Series Range Hoods are designed to respond to high amounts of smoke by increasing fan speed and dropping the suction plate by 4.7 inches to proactively remove smoke and other harmful odors.

4.7in

\* Adjustable Surround Suction plate available on EMG9030 only



# FOTILE's Innovative, High-Powered DC Inverter Motor

Discover quiet, yet powerful smoke extraction for a peaceful cooking experience.

## Astounding 100,000 RPH

Completing 100,000 rounds per hour, the direct-current inverter in your FOTILE W Series Range Hood ensures smoke and other unpleasant odors are extracted as quickly and thoroughly as possible.

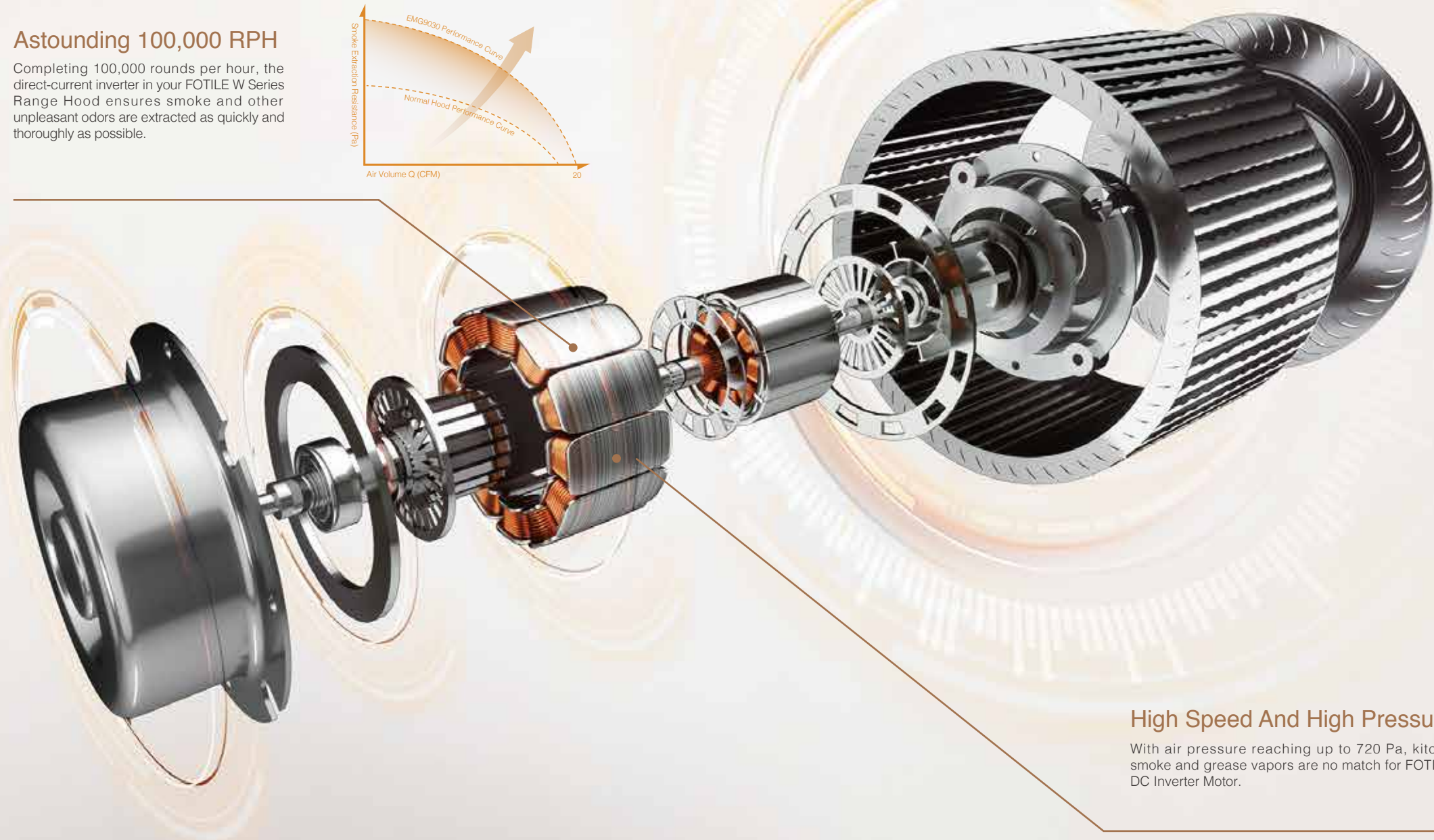
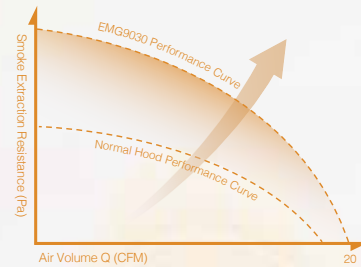

## High Speed And High Pressure

With air pressure reaching up to 720 Pa, kitchen smoke and grease vapors are no match for FOTILE's DC Inverter Motor.



### Smart Smoke Detection. Intelligent Suction. No More Stray Smoke.

FOTILE's intuitive, self-regulating W-Series Range Hoods offer smart functionality to adjust speed and height settings automatically, based on the volume of smoke and odors in your kitchen.

\* available on EMG9030 only



### Auto Turbo System

If, at any point during the ventilation process, FOTILE range hood detects resistance, the unit will automatically switch to its most powerful mode for maximum extraction capacity.



### Intelligent Air Management Protects Your Home From Dangerous Gases

FOTILE's Intelligent Air Management function is designed to keep your home safe and clean at all times. Enjoy peace of mind knowing your range hood is capable of identifying and extracting the following airborne pollutants: Formaldehyde, Ammonia, Carbon monoxide (CO), Benzene, Cigarette smoke, Residual cooking smoke...and more!

Be sure to turn on Intelligent Air Management - even when you're not cooking!

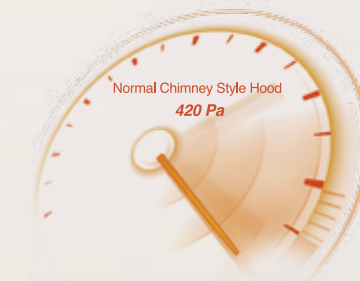

FOTILE W 720 Pa





**EMG9030**



**EMS9016**

<b>Product Size(in)W*D*H</b>	35 7/16*20 5/16*(25 7/16-37 1/16)	35 7/16*20 7/8*(23 3/4-37 1/2)
<b>Power Supply</b>	120V/60Hz	120V/60Hz
<b>Motor Power(W)</b>	262	310
<b>Motor Type</b>	DC	AC
<b>No. of Speed</b>	4(T)	2+T
<b>Normal Noise(dB)</b>	51.5	50
<b>Max Static Pressure(Pa)</b>	720	397
<b>Illumination Power(W)</b>	2*2	2
<b>Auto Smoke Detection</b>	Y	N
<b>Intelligent Self-adjusting</b>	Y	N
<b>Intelligent Air Management</b>	Y	N
<b>Auto Turbo System</b>	Y	Y
<b>Delay-off function(min)</b>	2/5/10	2
<b>Control Mode</b>	Touch Control	Micro Light Touch



**EMS9018**

<b>Product Size(in)W*D*H</b>	35 7/16*20 7/8*(23 3/4-37 1/16)
<b>Power Supply</b>	120V/60Hz
<b>Motor Power(W)</b>	310
<b>Motor Type</b>	AC
<b>No. of Speed</b>	2+T
<b>Normal Noise(dB)</b>	50
<b>Max Static Pressure(Pa)</b>	397
<b>Illumination Power(W)</b>	2
<b>Auto Smoke Detection</b>	N
<b>Intelligent Self-adjusting</b>	N
<b>Intelligent Air Management</b>	N
<b>Auto Turbo System</b>	Y
<b>Delay-off function(min)</b>	2
<b>Control Mode</b>	Touch Control



## Patented Clean & Clear Filter

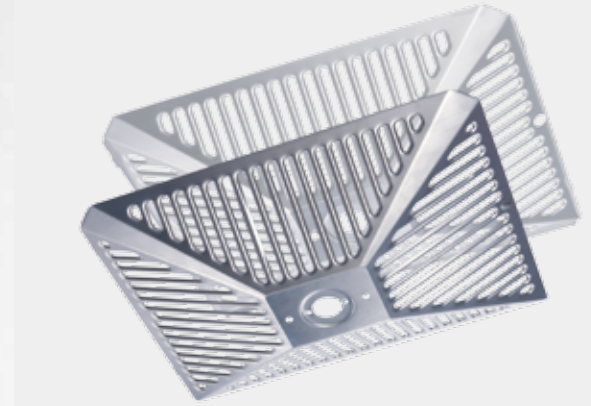

### Arc-shaped Design

The Cooking fume locks securely onto the lead tank and the air inlet ensures maximum air flow and minimal resistance.

### Double-layer Filter Design

The FOTILE double-layer filter is 2.5 times more effective than normal filters. This provides a stronger oil-filtration rate and maintains stronger turbine power.

### 25° Tilt Angle

The arc-shaped filter is designed at a 25° angle to prevent oil from dripping inside the unit.

## Nautilus Air Passageway

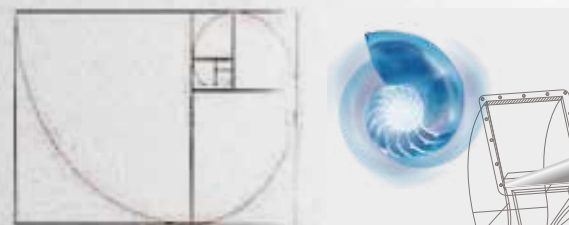

Inspired by Marine organisms, the Nautilus passageway features a smooth logarithmic design with sleek curves for smooth air flow, low resistance, and a reduction in air backflow. This maximizes the range hoods extraction power and minimizes noise from airflow.

## The Proprietary "Strong Motor"



The "Strong Motor", which is an innovative and original design created by FOTILE, ensures that noise level will always be contained to a minimum during the extraction process.

## Varied R Turbine System

Using the theory of aerodynamics, FOTILE has achieved a great reduction in noise utilizing a Varied R Turbine System.



## EH13

RANGE HOOD



### Features

Built-in air inlet design for quick extraction

Stainless Steel and Tempered Glass Surface

Easy to clean filter

Equipped with Gas & Heat Sensor that switches hood on automatically when gas or high temperature is detected.

High definition fingertip touch display

### Specification

Certification:	ETL
Product Size(in)W*D*H:	29 <sup>9</sup> / <sub>16</sub> * 20 <sup>1</sup> / <sub>8</sub> * (21 <sup>1</sup> / <sub>16</sub> - 35 <sup>5</sup> / <sub>8</sub> )
Noise Level(dB(A)):	58

## EH11D

RANGE HOOD



### Features

Built-in air inlet design for quick extraction

Stainless Steel and Tempered Glass Surface

Easy to clean filter

### Specification

Certification:	ETL
Product Size(in)W*D*H:	29 <sup>9</sup> / <sub>16</sub> * 20 <sup>1</sup> / <sub>8</sub> * (21 <sup>1</sup> / <sub>16</sub> - 35 <sup>5</sup> / <sub>8</sub> )
Noise Level(dB(A)):	58





# FOTILE EPS Series Cooktop

## E | EFFICIENT

### Step3 | Efficient Combustion

Utilizing larger size flame ports around the burner and oxygen flame cap, ensures the proper level of air intake through the inlets, maximizing efficiency.



### Step2 | Large Premix Compartment

Acts as a gas reservoir, letting in oxygen to combine with the fuel, and then releasing the mixture in a steady, unbroken stream



### Step1 | Jet Collision Technology

Initiates a high-speed collision of gas and oxygen within the extended chamber, ensuring thorough mixing for a steady flame.





# P | POWERFUL

The perfect burner can meet all types of cooking demands. Your FOTILE burner is suitable for any style of cooking, from stewing to deep-frying, and everything in-between.



# S | SAFE

12 built-in safety features for added reliability to insure the durability and safety of our product.

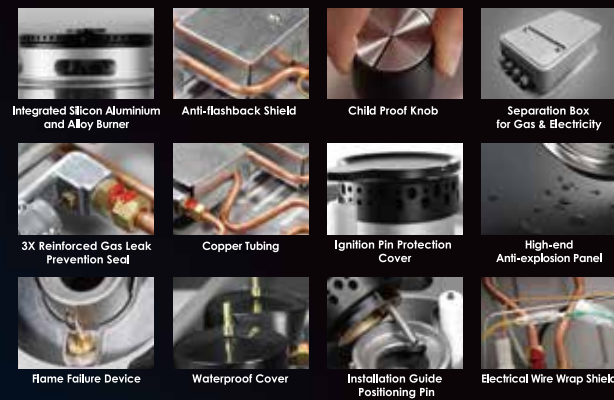

## GAG86309

EPS Cooktop



### Features

Stylish tempered glass surface

Increased heating efficiency of over 60% saves you Gas, Time, and Money

Suitable for any style of cooking

12 incredible safety features to insure the durability and safety of product

### Specification

Certification:	ETL
Panel:	Tempered Glass
Pan Support:	Cast Iron
Heating Load(BTU):	L/R 14800 M5800
Product Size(in)W*D:	33 <sup>7</sup> / <sub>8</sub> * 19 <sup>1</sup> / <sub>16</sub>
Built-in Size(in)W*D:	32 <sup>3</sup> / <sub>16</sub> * 18 <sup>1</sup> / <sub>8</sub>

## GAS78307

EPS Cooktop



### Features

Stylish tempered glass surface

Increased heating efficiency of over 60% saves you Gas, Time, and Money

Suitable for any style of cooking

12 incredible safety features to insure the durability and safety of product

### Specification

Certification:	ETL
Panel:	Stainless Steel
Pan Support:	Cast Iron
Heating Load(BTU):	L/R 14800 M5800
Product Size(in)W*D:	30 <sup>3</sup> / <sub>4</sub> * 17 <sup>3</sup> / <sub>4</sub>
Built-in Size(in)W*D:	27 <sup>7</sup> / <sub>8</sub> * 15 <sup>5</sup> / <sub>16</sub>



Member of HVI, the most authoritative and credible institution in North America



product design award







**FOTILE**  
**Master Series Ovens**



# CONSTANT TEMPERATURE

Tired of burning your favorite desserts and being let down? You don't have to worry about that anymore. It's easy to bake that perfect Macaroon so it is soft on the inside and perfectly crispy on the outside. Best yet, it will always be perfectly cooked through without having to stop, open the oven, and turn the tray. Now you can tantalize your taste buds with gourmet dishes you create in your professional-grade oven.



The unique design of the hot-air filter located at the back of the oven at a 172° angle helps balance the air volume to increase hot air flow and create the most stable inside temperature as possible.



To maximize efficiency and create an easy memorable baking experience, FOTILE has developed 10 baking presets to help make your perfect dish.



Our Platinum – alloy temperature sensor and five heating tubes, ensures you have precise control of your oven temperature.

# SIMPLE DESIGN

Our unmatched design features make our ovens the ultimate kitchen cooking appliance. When designing our products, we conduct countless hours of consumer research to ensure our products are simple, easy to use, and provide long lasting quality and enjoyment for you and your family.

## Oversized Window



A large window on the oven door provides a clear view of the oven's interior allowing you to see the baking process at any point in time.

## Damping hinge

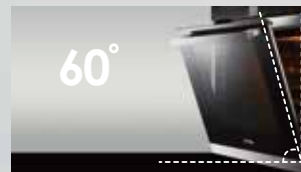

Our Oven door hinge creates a perfect balance at every angle the door is opened to. If the door is opened to a 60° angle, you can simply close the door with a small push, and it will gently close.

## Anti-Fall Grill

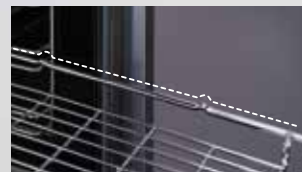

By creating a small notch in the grill rack, you can easily pullout the rack to get your food, and the rack will balance perfectly without dropping out of the oven.

## Easy to Use



We have created an oven that is simple to use with an easy three-step process. Simply chose the mode, select the temperature, and input your desired cook time. Then leave it up to the oven to make you look like a Professional.

## KSG7003A

OVEN



### Features

2.47 cu.ft. provides plenty of space for all your baking needs

Elegant Tempered Glass and Large Oversized Low-E Glass Window.

Hot Air Filter design allows for a more stable and even temperature.

10 baking presets for easy use and maximum efficiency

Damping hinge for soft closing door.

Rated for high energy efficiency

O-Touch elegant design

### Specification

Certification:	ETL
Rated Capacity:	2.47cu.ft.
Rated Voltage:	220-240V/60Hz
Product Size (in) W*H*D:	23 <sup>7</sup> / <sub>16</sub> * 23 <sup>7</sup> / <sub>16</sub> * 21 <sup>3</sup> / <sub>4</sub>
Built-in Size (in) W*H*D:	23 <sup>9</sup> / <sub>16</sub> * 23 <sup>9</sup> / <sub>16</sub> * (≥22 <sup>7</sup> / <sub>8</sub> )
Half Built-in Size (in) W*H*D:	22 <sup>1</sup> / <sub>16</sub> * 23 <sup>1</sup> / <sub>4</sub> * (≥21 <sup>1</sup> / <sub>16</sub> )

## KSS7002A

OVEN



### Features

2.47 cu.ft. provides plenty of space for all your baking needs

Elegant Stainless Steel and Large Oversized Low-E Glass Window.

Hot Air Filter design allows for a more stable and even temperature.

10 baking presets for easy use and maximum efficiency

Damping hinge for soft closing door.

Rated for high energy efficiency

### Specification

Certification:	ETL
Rated Capacity:	2.47cu.ft.
Rated Voltage:	220-240V/60Hz
Product Size (in) W*H*D:	23 <sup>7</sup> / <sub>16</sub> * 23 <sup>7</sup> / <sub>16</sub> * 21 <sup>3</sup> / <sub>4</sub>
Built-in Size (in) W*H*D:	23 <sup>9</sup> / <sub>16</sub> * 23 <sup>9</sup> / <sub>16</sub> * (≥22 <sup>7</sup> / <sub>8</sub> )
Half Built-in Size (in) W*H*D:	22 <sup>1</sup> / <sub>16</sub> * 23 <sup>1</sup> / <sub>4</sub> * (≥21 <sup>1</sup> / <sub>16</sub> )



## FOTILE STEAM OVENS



### Dual Effect Technology

Using an innovative Dual Steam Generator, our steam ovens are able to control the precise amount of steam for accurate control of the internal temperature.



### 1-degree Precise Temperature Control

Precise temperature control is a key factor when preparing delicious meals. FOTILE steam ovens have a temperature deviation that do not exceed 1°.



### 100% Steam Heating System

Our one hundred percent steam heating technology retains more nutrients within your food. The external steam generator cooks food perfectly to insure healthier and tastier meals.

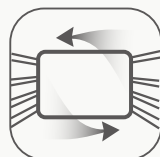

### Dynamic Steam Balance System

The Steam Oven has air inlet and outlet that ensures the right amount of steam is produced to cook food properly, thoroughly, and deliciously so that you can enjoy its wonderful taste.

## SCD26-C2S

STEAM OVEN



### Features

Two steam generators make it taste better

8 programmable functions

Precise temperature control system

Fashionable O-TOUCH series and simple to clean

### Specification

Certification:	ETL
Rated Capacity:	0.92cu.ft.
Rated Voltage:	220 - 240V/60Hz
Product Size (in) W*H*D:	23 <sup>7</sup> / <sub>16</sub> * 17 <sup>15</sup> / <sub>16</sub> * 20 <sup>1</sup> / <sub>4</sub>
Built-in Size (in) W*H*D:	23 <sup>9</sup> / <sub>16</sub> * 18 <sup>1</sup> / <sub>8</sub> * 21 <sup>11</sup> / <sub>16</sub>
Half Built-in Size (in) W*H*D:	22 <sup>1</sup> / <sub>16</sub> * 17 <sup>3</sup> / <sub>4</sub> * 21 <sup>11</sup> / <sub>16</sub>

## SCD26-D1

STEAM OVEN



### Features

Two steam generators make it taste better

8 programmable functions

Precise temperature control system

Elegant stainless steel series

### Specification

Certification:	ETL
Rated Capacity:	0.92cu.ft.
Rated Voltage:	220 - 240V/60Hz
Product Size (in) W*H*D:	23 <sup>7</sup> / <sub>16</sub> * 17 <sup>15</sup> / <sub>16</sub> * 20 <sup>1</sup> / <sub>4</sub>
Built-in Size (in) W*H*D:	23 <sup>9</sup> / <sub>16</sub> * 18 <sup>1</sup> / <sub>8</sub> * 21 <sup>11</sup> / <sub>16</sub>
Half Built-in Size (in) W*H*D:	22 <sup>1</sup> / <sub>16</sub> * 17 <sup>3</sup> / <sub>4</sub> * 21 <sup>11</sup> / <sub>16</sub>



## FOTILE MICROWAVE OVENS



### Microwave and Light Heating System

Microwave works in sync with Light Heating System for easy reheating and quick food preparation



### Simple, easy-to-control Instant Menus

Simple and easy to control. Prepare a full meal simply by clicking the desired option.

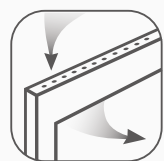

### Independent Ventilation System keeps kitchen air fresh and odor-free

Extracts odors using the Independent Ventilation System to keep your kitchen fresh and comfortable with no trace of residual odors left over.

## HW25800K-C2G MICROWAVE OVEN



### Features

Microwave and Light Heating System work together in sync to heat your meals quickly, easily, and perfectly.

Instant Menus are simple and easy to control

Independent Ventilation System keeps your kitchen fresh and comfortable with no trace of residual odors.

O-Touch elegant design

### Specification

Certification:	ETL
Rated Capacity:	0.88cu.ft.
Rated Voltage:	120V/60Hz
Product Size (in) W*H*D:	23 <sup>7</sup> / <sub>16</sub> * 15 <sup>3</sup> / <sub>16</sub> * 14 <sup>1</sup> / <sub>2</sub>
Built-in Size (in) W*H*D:	23 <sup>9</sup> / <sub>16</sub> * 15 <sup>5</sup> / <sub>16</sub> * 21 <sup>1</sup> / <sub>16</sub>
Half Built-in Size (in) W*H*D:	22 <sup>1</sup> / <sub>16</sub> * 14 <sup>3</sup> / <sub>16</sub> * 21 <sup>1</sup> / <sub>16</sub>

## HW25800K-03G MICROWAVE OVEN



### Features

Microwave and Light Heating System work together in sync to heat your meals quickly, easily, and perfectly.

Instant Menus are simple and easy to control

Independent Ventilation System keeps your kitchen fresh and comfortable with no trace of residual odors.

### Specification

Certification:	ETL
Rated Capacity:	0.88cu.ft.
Rated Voltage:	120V/60Hz
Product Size (in) W*H*D:	23 <sup>7</sup> / <sub>16</sub> * 15 <sup>3</sup> / <sub>16</sub> * 14 <sup>1</sup> / <sub>2</sub>
Built-in Size (in) W*H*D:	23 <sup>9</sup> / <sub>16</sub> * 15 <sup>5</sup> / <sub>16</sub> * 21 <sup>1</sup> / <sub>16</sub>
Half Built-in Size (in) W*H*D:	22 <sup>1</sup> / <sub>16</sub> * 14 <sup>3</sup> / <sub>16</sub> * 21 <sup>1</sup> / <sub>16</sub>



JQG9001/JQG7501/JQG7501.G/JQG7502/JQG7502.G

EH11D / EH13

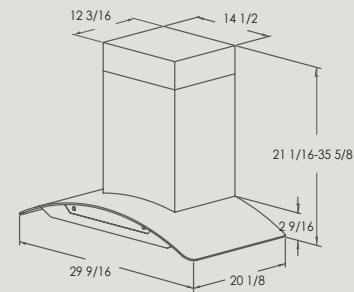
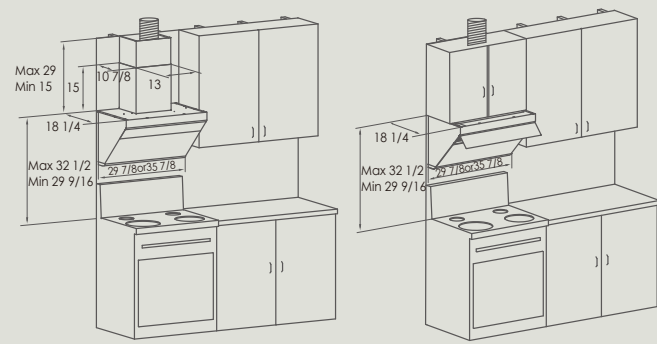

▲ Without upper cabinet+decorative cover    ▲ With upper cabinet

GAG86309

GAS78307

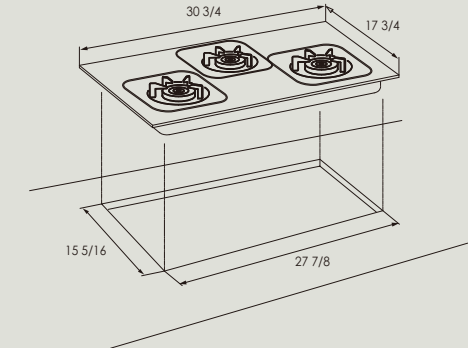
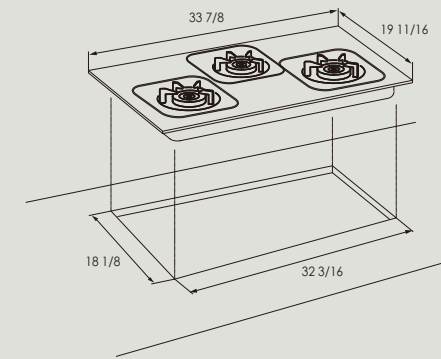

EMS9018

EMG9030

Hole Size of Cabinet on Top Surface

Installation diagram for the top decorative cover pothook.

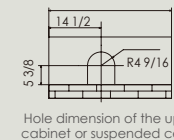
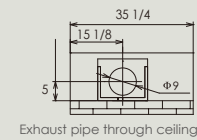
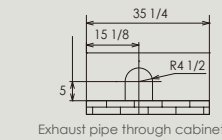

Hole dimension of the upper cabinet or suspended ceiling

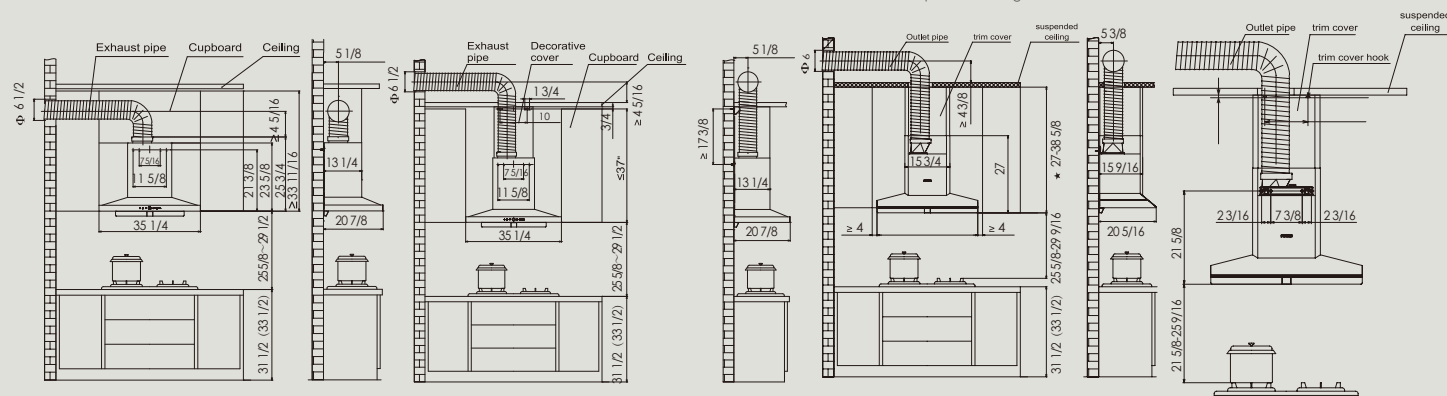

EMS9016

Hole Size of Cabinet on Top Surface

Installation diagram for the top decorative cover pothook.

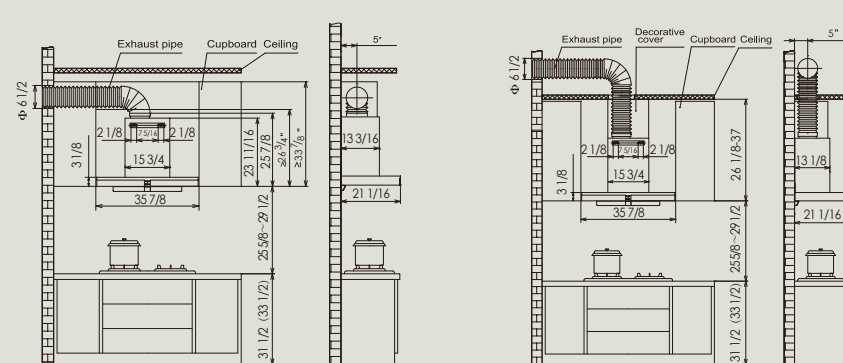
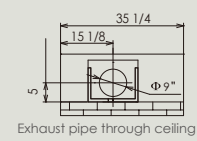
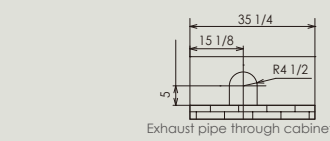

KSS7002A/KSG7003A

Full built-in

Half built-in

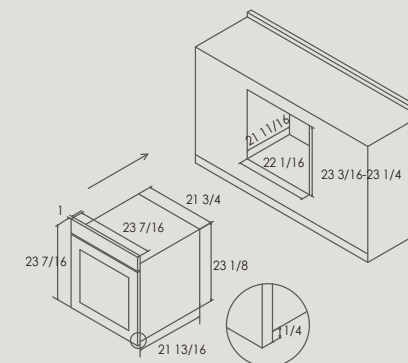
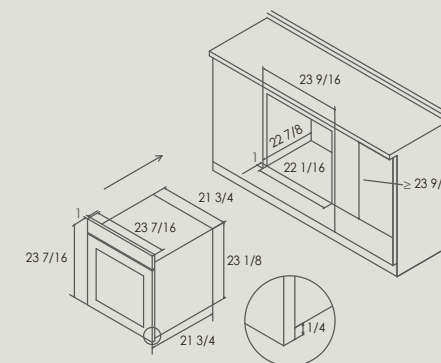

HW25800K-C2G(03G)

SCD26-C2S(D1)

Full built-in

Half built-in

Full built-in

Half built-in

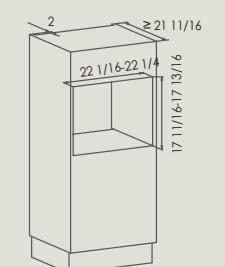
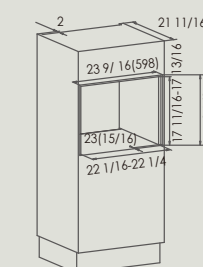
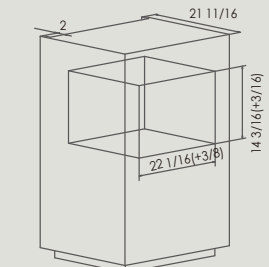
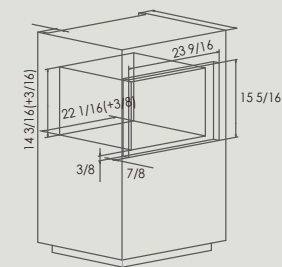

unit: inch